



ANG

JOB NAME:

FIXTURE TYPE:

ANGLE LUMINAIRE

FEATURES

- Unique corner mount design for direct downward and outward illumination.
- Same unit can also be used as cove lighting for indirect upward and outward illumination.
- Available in 2', 3', and 4' lengths, in 1, 2 and optional 3 lamp configurations, T5, T5HO and T8.
- Optional housing with continuous piano hinge doorframe and tamperproof fasteners for high security applications.
- For individual or row mounting.
- Available in custom finishes to match most décor's.
- Available with energy efficient reflectors in specular silver (95% reflectance) or specular aluminum (85% reflectance).

SPECIFICATIONS

- **HOUSING**
Die formed heavy gauge steel housing and ends unitized into one piece.
- **ELECTRICAL**
Electronic instant start HPF ballasts comply with Federal Energy Efficiency standards.
- **SHIELDING**
Acrylic prismatic lens is standard. Numerous optional shielding media available for normal, medium, and maximum security applications. Refer to **Options**.
- **FINISH**
All metal parts are painted after fabrication with premium white enamel with a minimum of 89% reflectance applied over ion phosphate pretreatment for maximum adhesion and rust resistance.
- **CERTIFICATION**
All units bear UL and Made in U.S.A. labels.



Angle Luminaire

Ordering Matrix

CATALOG NUMBER T8	LAMPS	LENGTH	CATALOG NUMBER T5	LAMPS	LENGTH
ANG-117	1-F17	24"	ANG-214T5	2-F14T5	24"
ANG-217	2-F17	24"	ANG-224T5-HO	2-F24T5HO	24"
ANG-125	1-F25	36"	ANG-221T5	2-F21T5	36"
ANG-225	2-F25	36"	ANG-239T5-HO	2-F39T5HO	36"
ANG-132	1-F32	48"	ANG-228T5	2-F28T5	48"
ANG-232	2-F32	48"	ANG-254T5-HO	2-F54T5HO	48"

Options:

- Tamperproof Hardware – suffix TP
- Tamperproof Screwdriver – suffix TSD
- 1/8" Thick Polycarbonate Lens – suffix LEX
- Vandal proof Housing (with piano hinge frame) – suffix VP
- Louver/Lens Vented Shielding – suffix L/L
- Specular Silver Reflector – suffix SS95
- Specular Aluminum Reflector – suffix SA85

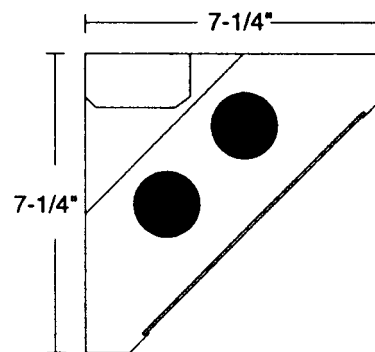
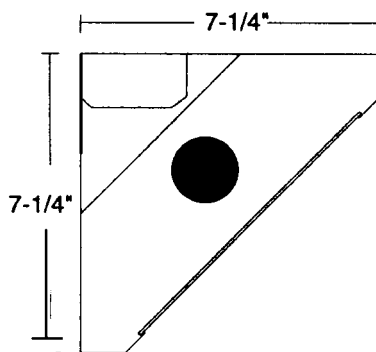

*For critical application verify all dimensions with factory.
 For additional Lamp/Ballast options, consult factory.
 For 3 lamp version, consult factory.*